

EZ View Display

Innovation
For Results®

Maximum Brand Impact!

Easy to see... Easy to set-up!
One purchase... a lifetime of use.

Don't be shy with your brand or message. The EZ View system takes advantage of a customer's natural sight lines. No more straining or craning for your brand to be seen. Best of all, the EZ View requires no floor space! Simply hang it over your display or aisle for best results. Sets up in minutes. Changing graphics is easy.



XtraFlex "Easy Connect"
Frame System

Double Sided
Display Assures
Maximum Impact.

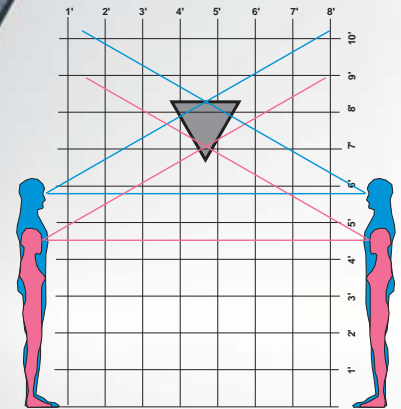

When positioned correctly for natural sight lines,
EZ View provides greater impact and brand retention.

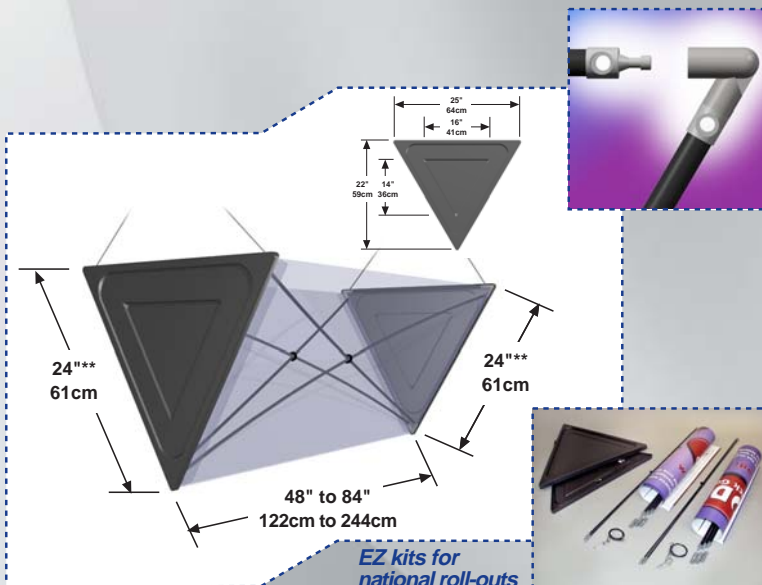

EZ kits for
national roll-outs

- Bi-directional viewing for greater effectiveness
- EZ View ergonomic viewing angles
- Great attention grabber
- Installs easily and quickly
- Change graphics with ease
- Lifetime Repair and Replace Warranty*

* One Year Limited Warranty on end caps.